

ELITISME

ELITISME WORKING PAPER SERIES

ANR-ELITISME-2015-007

Modelling mode choice within couples

Nathalie Picard

Sophie Dantan

André de Palma



Labex MME-DII

Modèles Mathématiques et Économiques de la Dynamique, de l'Incertitude et des Interactions.



Modelling mode choice within couples

Nathalie Picard^{1*} Sophie Dantan² André de Palma³

November, 2015

ABSTRACT

We analyze couples mode choice, with an application in Paris region. When spouses' commuting decisions are assumed to be independent – the standard assumption – the model poorly reproduces intra-household decisions. We set up a model of joint decision, which provides more plausible results and exhibits a greater predictive power. We estimate the determinants of the bargaining power (spouses' age, nationality, type of job contract, tenure status and number of children) using a collective model. To control remaining endogeneity issues, we finally model the joint choice of car ownership and mode choice. Values of time are computed for driving alone and together.

JEL classification: R2, R4

Keywords: Commuting, mode choice, unitary models, collective models, endogeneity, car ownership.

* Corresponding author

¹ Thema, University of Cergy-Pontoise, 33 boulevard du Port, 95000 Cergy and Ecole Polytechnique, Université Paris-Saclay, Route de Saclay, 91128 Palaiseau

² Centre d'Economie de la Sorbonne, ENS Cachan, Université Paris-Saclay, 61 avenue du Président Wilson, 94230 Cachan, France – nathalie.picard@u-cergy.fr

³ Centre d'Economie de la Sorbonne, ENS Cachan, Université Paris-Saclay, 61 avenue du Président Wilson, 94230 Cachan, France and KU Leuven, Oude Markt 13, 3000 Leuven, Belgium

1. Introduction

Mode choice, typically, involves the choice between public transport (transit) and private transport (car). It is an important component of short-run mobility and in the long term it is essential to explain urban development. Mode choice is also a crucial step in the standard four-step forecasting procedure (along with route choice, trip generation and trip distribution). It has been studied during almost half a century in Transportation (see De Donnea, 1971) and is associated to the development of discrete choice models (see Warner, 1962) and to entropy models (see Wilson, 1965). Mode choice or the study of mode split is also associated to Micro economics, Operations Research, marketing and psychology (see Bronner, 1982) *inter alia*. Mode choice decisions are important from a practical point of view since they represent a major component of accessibility, car usage and activity based models. In the short run, car ownership is fixed. In a longer run, mode choice interacts with car ownership, and with residential and professional location (Anas and Moses, 1979; Anas and Xu, 1999). Moreover, mode choice is necessary to compute the Value Of Time (denoted by VOT; see, e.g. Train and McFadden, 1978). VOT depends on the mode chosen (as will be verified in this paper), but also on the purpose of the trip. We show in this paper that mode choice decisions differ between men and women (and show how it depends on other individual characteristics). We also show how it depends on the bargaining process within the family.

Interestingly, our empirical results show that the value of time depends on how the car is shared by men and women, one important aspect that has been neglected in the literature so far. We show that the VOT is not the same depending on whether the man or the woman drives the car (if both spouses commute in the same car). This paper considers an application in the Paris region (Ile-de-France) where car occupancy is still low, as in in many developed countries. For example, in the Paris region, it is 1.1 per car, for commuting trips. However, it is higher for non-commuting trip and up to 1.59 for leisure and visit (see DRIEA, 2013). Due to new modes of transportation, such as carpooling or car sharing, occupancy rate is likely to increase. Therefore it is important to be able to develop a methodology to compute the VOT when car is shared, as well as to better understand the determinants of such joint decision. We restrict our analysis to a specific and well defined situation: the family. We will study the usage of car in two-earner couples (married or not), which may, or not have to share the same car.

This paper will provide a first step to better analyze car sharing, discounted rental cars in the new emerging transportation environment, which remain very poorly understood so far, even though large data sets (Big Data on individual behavior and mobility pattern) are accumulated by major companies (such as IBM, Orange or Siemens) or by new rapidly growing companies (such as BlaBlaCar or VroomVroomVroom, for example).

In the standard framework, one individual is facing one, two or more modes for each specific trip and s/he selects the most attractive one. We wish to extend this framework, when the decisions of the two commuters (in the same couple) are interdependent, since they may use the same car. If spouses decide to use the same car, it remains to know who drives. We will determine how to compute the VOT (and the fixed cost) taken into account by each decision

maker when spouses commute together, and compare those values, with the standard ones, that can be derived when we make the wrong assumption that the commuting decisions of spouses are independent.

When sharing a car is an option, it is necessary to provide a description of the bargaining process (or of the joint decision process) which takes place in the family. The couple may have more or less conflicting objectives, which take into account physical constraints (being on time at work, for example) and preferences (willingness to spend some time with the other spouse, for example). Clearly man and woman are able to different extent to influence the joint decision made by the couple. The interdependence of spouses' mode choice decisions is described using a bargaining model. The respective importance of the man and the woman in the decision process is measured by their respective importance in the joint decision process. This respective importance of each spouse is measured by the *Pareto weights*. We estimate these Pareto weights simultaneously with spouses' respective values of time, thus disentangling the roles of preferences and bargaining process in couple mode choice decisions. The Pareto weight depends on socioeconomics characteristics, as discussed along with our econometric estimations of the joint models.

The understanding of joint couple decisions is central in the evaluation of public policies, as underlined by Vermeulen (2002b) in the context of labor supply. Taking into account the joint nature of couple decisions is especially important when one spouse's decision induces externalities on the other spouse, which is the case both in labor supply (through joint taxation) and in mode choice (competition for using the car or differential value of time when commuting together or alone). In the departure time context (see de Palma et al., 2015), when a spouse leaves home, he/she imposes an externality on the other spouse.

A number of policies, such as toll, parking fee, dedicated lane, zoning, etc. affect mode choice. The responses however depend on the way the car is used in the couple. The car can either stay in the garage, or be used by any member of the family (with a driving license). Responses to policies, and car usage, could not be understood without understanding the bargaining process within the family. Recently, de Palma et al. (2015) have shown that when couples commuting by car coordinate their departure time decision, this may lead (in aggregate) to more congestion on the roads. When studying the global impact of transport policies, it is important to know how each spouse reacts to policies, how they benefit individually or are impacted by such policies, and how micro decisions aggregate. The heterogeneity within the family is as important as the heterogeneity between families.

In Section 2, we introduce briefly the bargaining models and collective models, used in the economics of the family. We also discuss the difference between individual and joint decisions. The data on Paris region are presented in Section 3. In Section 4, we start with the simplest model by assuming that mode choices made by spouses are independent choices. We then discuss the results which suggest that the independence hypothesis (although standard in the literature) is not valid. In Section 5, we develop a more realistic model in which spouses jointly choose their mode by maximizing a weighted average utility of the man and the woman. In this section, we still assume exogenous car ownership. The weights are referred to

as Pareto weights and measure the spouses' respective bargaining power. The problems discussed in Section 4 are less severe in Section 5, but still important. Estimations of Section 5 suffer from potential biases due to the endogeneity of car ownership. Indeed, the endogeneity is due to the fact that the number of cars, which is a key determinant of mode choice, is chosen by the couple. To correct for these endogeneity biases, we estimate in Section 6 a joint mode and car ownership model and compare the results to those of the previous models. Our estimates suggest significant differences in VOT of spouses when they travel alone by car or together. The results are considerably improved with the estimate of mode choice. Section 7 concludes.

2. Mode choice: Individual or joint decision?

In the economic literature, family models considering a single decision maker are usually referred to as *unitary* models (see Becker, 1965, 1991). Many researchers, especially in family economics, criticize this assumption, questioning the hypothesis that the behavior of multi-person households can be described by a single decision-maker model satisfying the basic preference axioms or the income pooling property: according to this hypothesis, no matter who earns income in the family, it is spent the same way. Such criticisms are recognized informally by some researchers in urban economics, but not yet formalized in the study of mode choice and car ownership (see Chiappori et al., 2014 and de Palma et al., 2014).

Different research streams concerned with household decisions have been developed independently in transportation, time and task allocation, or residential location. However, most of these contributions are unitary models since households are treated as a single decision-making unit. As a consequence, the interactions within the household are not explicitly modeled and the outcomes of the decision-making process are considered as resulting from a representative individual as if the household were a black box which did not need be opened.

Recently, researchers in the urban and transport context have started to study the family determinants of choices affecting the family (Abraham and Hunt, 1997; Bhat and Pendyala., 2005; Timmermans, 2006; Timmermans, 2009; Beharry-Borg et al., 2009) even though they did not yet study the within-family bargaining process. In this literature, household interactions are either introduced through explanatory variables defined at the household level, or simply disregarded. Examples of household-level explanatory variables are number of household (active) members, number of children as well as household income, and other household dummy variables (e.g., household head occupational status, tenure status, age, etc.).

By contrast, collective models (Chiappori, 1988, 1992) recognize that household decisions result from a bargaining process involving several decision-makers with individual-specific bargaining power. These non-unitary models developed in the economics of the family literature do not merely extend existing unitary model, and the discrete choice framework. They introduce new concepts specific to within family interactions: negotiation, altruism,

repeated interaction and Pareto optimality (See the survey Vermeulen, 2002a and Browning et al., 2014).

When there is more than one decision-maker in the household, a complex bargaining process usually takes place. Since the 80's, economic literature has developed models analyzing the within-family bargaining process in other contexts such as labor supply or consumption (see Lundberg and Pollak, 1993). Chiappori (1988) developed the collective model, which explicitly recognizes that multi-person households face joint decisions involving partially altruistic members. In such models, decisions are assumed to be *Pareto-optimal*. When spouses jointly make decisions, the outcome is Pareto-optimal, if it is not possible to make one spouse better-off without making the other spouse worse-off. Pareto-optimality hypothesis seems natural for analyzing household decisions since family members, who interact over a long period, are probably able to find mechanisms leading to efficient decisions. Pareto-optimality can be tested empirically, and is usually not rejected. By contrast, the assumptions and/or conclusions of unitary models are usually rejected in multi-person households.

The bargaining process, essential in collective models, can be either explicit (as in McElroy and Horney, 1981 or in Lundberg and Pollak, 1993), or non-specified (as in Chiappori, 1988, 1992). In this paper, the use of a single car in the dual-earner couple will be the outcome of a Pareto-optimal bargaining process.

As shown in Chiappori (1992) collective models can be used to study the welfare level of each household member, and therefore to analyze and measure in a consistent way the redistributive effects of any economic policy, not only at the household level but also at the individual level. More specifically, Chiappori (1992) showed that, under some rather plausible conditions, individual utility functions can be recovered from household behavior and disentangled from bargaining power effects, whereas bargaining effects induce a bias in the measurement of preference parameters in unitary models.

In this paper, we introduce a collective model in urban and transport economics, to describe joint mode choice and car-ownership within the family. We focus on spouses' mode choice for commuting trips (home to workplace). Our models allow us to estimate the value of time (up to a multiplicative constant). In this preliminary analysis, we assume fixed residential and work locations. We recognize explicitly that the decision to buy or to use a car are not individual-specific but joint decisions. First, the car is often a public good, which is shared by several members of the household. Second, the purchase cost and the variable costs of the car are fully or partially supported by the different family member. At the same time, if the house or the apartment has a garage, it has to be paid by the different members of the household, in a way or another.

Since the late 1990s, transport economics has introduced the family dimension to analyze mode choice decisions. For example, Abraham and Hunt (1997) use a logit model structure with a system for weighting the contributions of different workers to the household utility in a three-level nested logit (residential location, workplace, and mode choice). However, these weights merge the individual preferences (spouses' Values Of Time) and bargaining powers,

or Pareto weights. As far as we know, the within family decision processes determining together mode choice and car ownership have not yet been investigated in the literature. However, these questions have been investigated for long time from the individual point of view. For example, according to Lerman (1977), household location decisions are closely related to other choices (disaggregate choice theory) such as automobile ownership, and mode to work. Even in a simplified static world, the joint purchasing decision is complex, since the underlying implications are often complex: Who uses the cars, who pays for gasoline, repairs, etc.? This paper proposes a first model of joint decision of car ownership and mode choice in the household.

Mode choice is a major topic in transportation economics. Since the first paper using the binary Logit to study modal choice by Warner (1962), a large literature based on discrete choice models (see, e.g. McFadden and Train, 2000; Ben-Akiva and Lerman, 1985) has emerged. In this paper, we use the individual discrete approach as a starting point to analyze joint mode choice decisions. Using this approach, we explain rivalry between decision makers for using the single car in the household. We focus here our attention on a specific situation (commuting), where the use of a car is an alternative to the use of public transit. Selecting the car rather than public transit may result in different outcomes with respect to travel cost, travel time, travel distance or generalized cost (and risk). When there is a single car in a dual-earner household, the use of a private car by the household members is necessarily a joint decision, rather than the outcome of independent choices. The final choice depends on the individual value of time, work schedule, some constraints (such as picking-up children) and the constraints that each spouse imposes on his/her partner, in a manner that remains unclear in the literature until now.

The challenges in this research are (1) to understand the way these individual characteristics get combined (2) to understand the way joint decision are made, and (3) to study how this affects the value of time. We know that the value of time is not the same in public and in private transportation. We plan to go one step ahead, and show that the value of time is not the same according to the fact that man is driving or is a passenger (for the same trip, with the same person).

3. Data

Paris Region (Ile-de-France) is composed by 8 *départements*: Paris city (CBD and historical center), 3 *départements* (counties) around Paris (Inner ring), and 5 *départements* farther away (Outer ring). Paris city concentrates a majority of the jobs, has a very dense public transportation network and a very congested private transportation network. The majority of households live in the Outer ring. The 8 *départements* are subdivided in 1300 communes (including 20 *arrondissements* in Paris city). In the Outer ring, communes are very small (some of them include less than 100 inhabitants).

Our study relies on data from the 1999 Census in Paris Region, which comprised more than 10 million inhabitants in about 5 million households. This census data provides detailed

information about both residential location and workplace location in a 5% sample⁴, as well as standard socio-economic characteristic, car ownership and usual mode for commuting trips.

	Number		% with 0 cars		% with 1 car		% with at least 2 cars	
Total	36,997		5.62		44.70		49.67	
Residence in Paris	4,766		22.39		59.44		18.17	
Residence in Inner ring	13,647		4.63		45.24		50.13	
Residence in Outer ring	18,584		2.06		40.52		57.41	
# children aged 0-3>0	7,090		5.06		49.53		45.40	
# children aged 4-6>0	6,219		4.92		46.29		48.79	
# children aged 7-11>0	8,866		4.06		42.22		53.72	
# children aged 12-16>0	7,929		3.73		41.19		55.08	
# children>0	20,795		4.36		44.70		50.94	
Man more educated than woman	6,683		5.52		45.14		49.33	
Woman more educated than man	8,872		4.40		44.95		50.65	
Tenure status=owner	21,147		1.92		36.10		61.97	
	F	M	F	M	F	M	F	M
Workplace in Paris	10,827	9,143	11.43	12.28	60.52	57.45	28.05	30.26
Workplace in Inner Ring	12,501	13,585	4.46	4.59	41.62	42.94	53.92	52.47
Workplace in Outer Ring	13,669	14,269	2.09	2.35	34.99	38.21	62.92	59.44
Occup="blue collar"	2,250	8,542	11.11	7.74	50.98	50.57	37.91	41.69
Occup=employee	15,563	4,510	6.59	10.16	49.98	54.70	43.44	35.14
Occup="professional"	11,443	9,892	3.71	4.01	40.69	45.32	55.61	50.67
Occup="white collar"	6,847	11,198	5.29	4.56	38.66	37.71	56.05	57.72
Occup="self-employed"	894	2,855	2.35	1.93	34.68	36.60	62.98	61.47
Foreign	3,271	3,732	16.81	16.21	52.40	50.19	30.79	33.60
Age<35	13,155	10,528	8.45	8.71	52.21	53.25	39.34	38.04
35<=Age<45	12,523	12,177	4.50	4.85	43.38	44.62	52.11	50.53
45<=Age	11,319	14,292	3.59	4.02	37.43	38.48	58.98	57.51

Table 1: Distribution of socioeconomic characteristics and car ownership for dual-earner couples

Note: F stands for "Female" and M for "Male"

Source: authors' computation on 5% sample of the 1999 Census of the population in Paris region

From the 5% sample of the population in Paris region, we have selected two-earner couples living and working in Paris region. We further restricted the sample to couples in which neither spouse is a farmer. We are left with 36,997 couples (56% of them have at least one child), corresponding to 73,994 individuals. We provide in Table 1 the distribution of the number of cars as a function of household and spouses characteristics, for dual-earner couples.

The proportion of households owning 2 cars is lower and the proportion of households without a car higher in Paris compared with the suburbs (Inner and Outer rings). In particular, in the Outer Ring, where public transport infrastructures are less dense and where parking

⁴ The job location is not available for the remaining 95% of the census sample. However, this 5% is selected so as to be representative of the whole sample.

places are easier to find, few households have no car, while those with 2 cars represent more than a half of the sample. Workplace location influences the car-ownership in a similar although less pronounced way: individuals working in the Inner or Outer Ring are more likely to own a car than those working inside Paris (see Figure 1).

Only a minority of couples with children and homeowners have no car. Car-ownership increases with the age of the family members (both parents and children). Blue-collar and employees are more likely to own no car and less likely to own two cars than professionals, white-collar and self-employed workers. Foreigners are also less likely to own a car than French people.

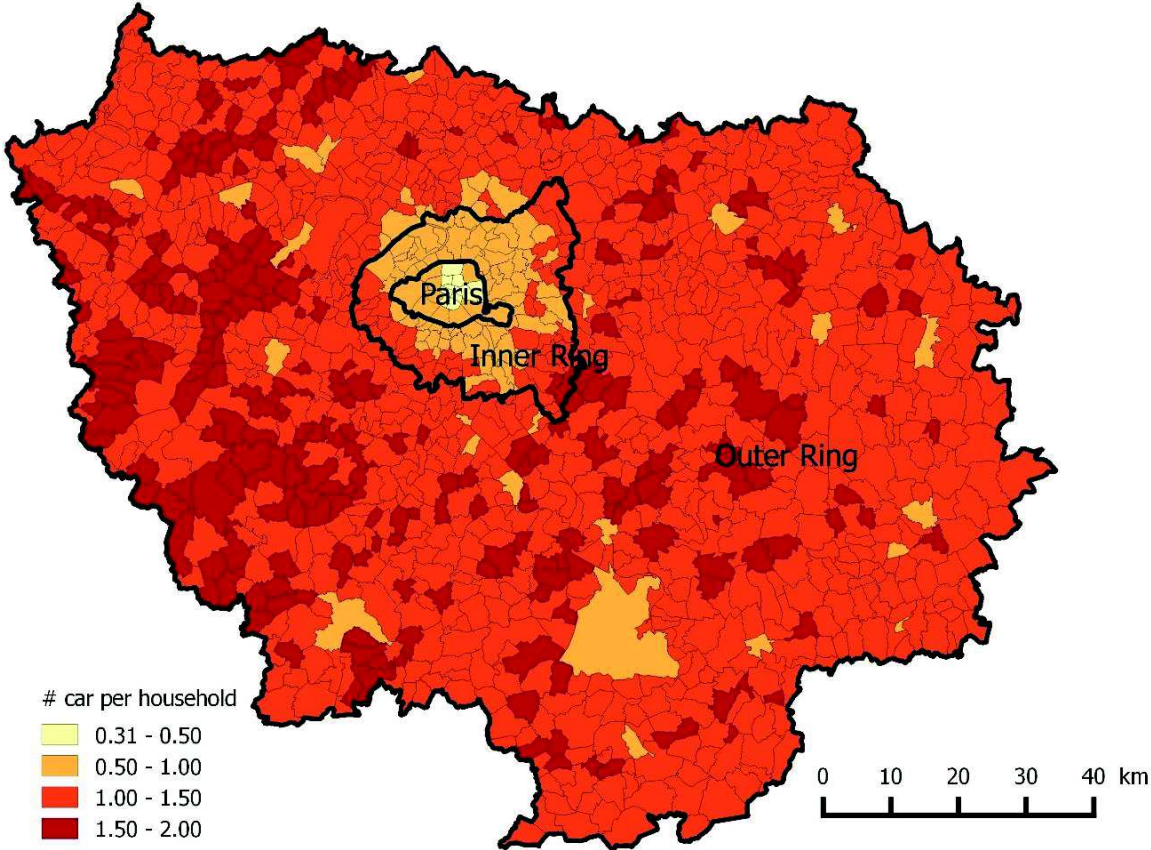

Figure 1: Car ownership by commune

Source: authors' calculation from 1999 Census

Table 2 provides the distribution of the joint mode choices in our sample. A mode choice is denoted (j, j') , where j stands for the mode of the woman and j' for the mode of the man. Modes can be either C or B , where C denotes the Car and B denotes the transit (Bus). Unsurprisingly, the number of cars owned by a couple increases the probability that both spouses commute by car while it decreases the probability that both commute by transit. When a household owns 1 car, the probability that the man drives while the woman commutes by transit is 2.4 times higher than the probability of the reversal. When it owns 2 cars, this ratio falls to 1.7. The distribution of the joint mode choice by residence and workplace is consistent with the distribution of the number of cars in Table 1.

We rely on the transport model MODUS (developed and calibrated by DRIEA, in charge of transportation studies in Paris region), which also contains 1300 zones. These zones are different from the communes: they are typically smaller inside Paris city and in the inner ring than in the outer ring. Each zone is represented by a “centroid” which can be a representative origin or destination in the corresponding zone.

Selected mode joint (F, M)	(C,B)	(B,C)	(B,B)	(C,C)
Total	10.41%	22.39%	20.44%	46.76%
0-car	-	-	100% ⁵	-
1 car	14.60%	35.64%	27.94%	21.82%
2 cars	7.82%	13.01%	4.67%	74.50%
Residence in Paris CBD	7.49%	25.72%	52.01%	14.77%
Residence in Inner ring	10.46%	24.44%	18.57%	46.54%
Residence in Outer ring	11.13%	20.04%	13.71%	55.12%
Workplace (F,M)				
Paris, Paris	5.04%	19.74%	62.59%	12.63%
Paris, inner ring	3.08%	51.86%	32.37%	12.69%
Paris, outer ring	1.39%	67.46%	18.04%	13.11%
Inner ring, Paris	30.74%	11.56%	35.60%	22.10%
Inner ring, inner ring	8.06%	18.20%	12.80%	60.94%
Inner ring, outer ring	6.95%	26.72%	7.12%	59.21%
Outer ring, Paris	45.17%	6.87%	19.55%	28.42%
Outer ring, inner ring	18.08%	11.59%	7.11%	63.21%
Outer ring, outer ring	6.35%	11.33%	4.48%	77.84%

Table 2: Distribution of joint mode choice

Note: F stands for “Female”, M for “Male”, B for “transit (Bus)” and C for “Car”. (C, B) means the woman uses the car while the man uses transit.

Source: authors’ computation on 5% sample of the 1999 Census of the population in Paris region

The travel times were computed for each Origin-Destination pair for each mode using two different models. For public transportation, we use the generalized travel time as computed by the model MODUS. The generalized time is the sum of travel time on each sub-path (bus, tramway, metro, RER, train) of the public transport network and of the access, egress and transfer time. For private transportation, we rely on the output of the dynamic private transport model METROPOLIS that was calibrated on the basis of observed travel times and flows⁶.

From this, we have computed commuting time of each spouse with each for the two transportation modes (car and transit). In addition, we also computed travel time between the two spouses’ workplaces, which is relevant in case one spouse drops the other one at her/his workplace before going to his/her own workplace. All these travel times are truncated using a lower bound of 1 minute and an upper bound of 240 minutes. The results are sum up in Table

⁵ This proportion is equal to 100% because we excluded from the sample couples in which one spouse does not commute by transit or by car.

⁶ In METROPOLIS, the travel time depends on the time of the day. In the current analysis, we have no information about spouses’ departure times, so that we rely on an “expected” travel time computed as the log-sum of the logit departure time choice model used. The departure time decisions within couples were explored by de Palma and Marchal (2002).

3. In most cases, women’s travel time to work is found to be lower than men’s, which is consistent with the fact that households tend to live closer to women’s workplace in Paris region (except in Paris, see Picard et al., 2013, Picard et al., 2015).

Table 3 suggests that commuting mode choice is efficient in the sense that the fraction of individuals choosing public transport is larger when the ratio of commuting time by transit to commuting time by car is lower. For example, this ratio is 1.95 or 2.05 for women commuting by transit, whereas it is 2.63 or 2.93 for women commuting by car, depending on the mode chosen by their husbands. Similarly, this ratio is 1.78 or 1.98 for men commuting by transit, whereas it is 2.36 or 2.66 for men commuting by car, depending on the mode chosen by their wives.

Selected mode (F,M)	All	(C,B)	(B,C)	(B,B)	(C,C)	0 car	1 car	2 cars
Woman’s travel time by transit (B)	49.08	45.58	48.79	42.78	52.76	36.13	45.80	53.51
Woman’s travel time by car (C)	26.57	21.71	34.44	29.12	22.76	20.67	27.62	26.29
Mean travel time ratio B/C, for F	2.50	2.63	1.95	2.05	2.93	2.32	2.28	2.71
Man’s travel time by transit (B)	55.53	57.89	52.16	45.65	60.94	38.82	50.76	61.72
Man’s travel time by car (C)	30.51	41.55	27.78	31.02	29.13	22.32	29.81	32.06
Mean travel time ratio B/C, for M	2.36	1.78	2.36	1.98	2.66	2.28	2.23	2.50
Travel time by car from man’s to woman’s job	26.39	30.02	34.00	19.98	24.73	20.11	25.76	27.66
Travel time by car from woman’s to man’s job	26.38	39.68	27.04	19.67	26.04	19.68	24.77	28.59
Extra time if man drives woman: % total direct commuting time	47.36	40.39	59.22	40.35	46.30	50.21	47.37	47.03
Extra time if woman drives man: % total direct commuting time	59.01	80.05	52.87	47.63	62.24	56.94	56.05	61.91

Table 3: Travel time distribution (* in % of the direct travel time)

Source: authors’ computations on 5% sample of the 1999 Census of the population in Paris region

In the two bottom lines of Table 2, each extra-travel time corresponds to the commuting time of a spouse when s/he drives the other to her/his workplace before going to his/her work (that is, the commuting time to the other spouse’s workplace plus the time from this workplace to own work) minus the commuting time directly from home to own work. It is expressed in percentage of the sum of the spouses’ travel times if both of them commute directly to work by car. The extra-time if the man drives the woman to her job, is on average identical in couples with 1-car and 2-car couples while the extra-time when the woman drives the man is significantly higher in 2-car couples than in 1-car couples: this suggest that this extra-time of woman might be a determinant of the ownership of a second car.

4. Independent model

4.1. Individual choice sets and Binary Logit

To explain the choice of spouses’ travel modes, different discrete choice models are estimated and compared in Sections 4 to 6. In this section, we make the standard assumption that the decisions of the two spouses are independent. In the next sections, we describe explicitly the joint mode choice decision and compare the two sets of results. The gender of the spouse is

denoted by G with $G \in \{F, M\}$, where F denotes the woman (Female) while M denotes the man (Male). To simplify the analysis, we only consider heterosexual couples. Let U_{iG}^j be the indirect utility of spouse G in couple i using transport mode $j=C, B$, where C denotes the Car and B denotes the transit (Bus).

We assume that the indirect utility function of spouse G in couple i using mode j is the sum of a deterministic (or measured utility) V_{iG}^j and an error term ε_{iG}^j :

$$U_{iG}^j = V_{iG}^j + \varepsilon_{iG}^j, j=C, B. \quad (1)$$

The error term measures taste heterogeneity. We postulate a linear utility function for the measured utility:

$$V_{iG}^j = \alpha_{iG}^j - \beta_{iG}^j \cdot tt_{iG}^j, j=C, B, \quad (2)$$

where α_{iG}^j is the maximum utility of spouse G in couple i if s/he chooses mode j . The term α_{iG}^j corresponds to the fixed benefit net of fixed cost of commuting by mode j . For each mode j , we only consider the direct route (the shortest travel time route) from home to work, which is characterized by an average total commuting time tt_{iG}^j . The maximum utility V_{iG}^j is obtained when commuting time tt_{iG}^j is zero. The Value Of Time (VOT), denoted by β_{iG}^j , is assumed to be independent of the commuting time. It corresponds to the opposite of the marginal utility of commuting time. We consider that working time is fixed and exogenously given, so that leisure time is reduced by 1 minute for each additional minute of commuting time. See de Palma et al. (2015), for a generalization in which the VOT depends on circumstances (i.e. on the activities performed by spouses at the origin and at the destination). As a consequence, the VOT includes the marginal utility of (foregone) leisure time, which depends on socioeconomic characteristics of spouse G in couple i (see Vickrey, 1969). In addition, the VOT includes an additional marginal weariness of commuting, which also depends on mode j . For example, public transports are rather congested in Paris and in RER trains, which translates in a higher value of time (DRIEA, 2013).

In this section, we assume that each member of the couple independently chooses the mode j , which maximizes his/her indirect utility function U_{iG}^j , $j=C, B$. This maximization is made regardless of the utility and of the choice made by the other spouse. It is further assumed that error terms are independent and identically distributed according to a Gumbel distribution $G(0,1)$. Alternatively, it suffices to assume that the difference of error terms is logistically distributed. Standard computation (see, e.g. Anderson et al., 1992) shows that the probability of spouse G in couple i of selecting mode j is given by the binary Logit model as:

$$P_{iG}(j) = \frac{\exp(V_{iG}^j)}{\exp(V_{iG}^{jC}) + \exp(V_{iG}^B)}, j=C, B. \quad (3)$$

The choice probability of each member of the couple is made according to the same analytical expression. De facto, decisions are independent. There is sufficiently observed heterogeneity

in our data to justify that additional unobserved heterogeneity, as introduced in a mixed logit, is not necessary.

4.2. Estimation results for independent choices

The model is estimated separately for men and women. For each gender, we compare the estimates for the households with one car, with two (or more) cars, and in the pooled sample (one or two or more cars; see column "All" in Table 1). Households with no car are not considered here since, in such households, the choice set of each spouse is reduced to a single alternative, B. Results are displayed in Table 4.

In the subsample of households with one car, the subsample of households with two and in the pooled sample, the variance of the residuals is normalized to $\pi^2/3$. In this case, the VOT β_{iG}^j is defined up to a multiplicative constant, which is specific to each subsample. This implies that the values of the coefficients cannot be compared between the six columns, but the signs and significance levels of the coefficients can be compared across columns, as well as ratios of coefficients. The determinants of α_{iG}^C are discussed in Section 4.2.1, whereas the determinants of β_{iG}^j are discussed in Section 4.2.2.

4.2.1. Fixed net benefit of commuting by car rather than by bus

Without loss of generality, the constant term is normalized to zero: $\alpha_{iG}^B = 0, \forall i, \forall G$. Therefore, we estimate a constant term (intercept) only for the car (drive) alternative, denoted "Intercept (drive)". Our estimates show that the intercept α_{iG}^C depends on workplace, occupation and nationality for both genders and on the number of children (by age group) for the women. Preliminary results (not reported here) show no effect of the number of children on the intercept α_{iG}^C for the men.

The reference individual is a 40 year-old French employee without children, working in Paris. For this reference individual, the intercept is negative for the women whatever the number of cars, which means that, if both commuting times were zero, the women would rather commute by bus than by car, especially when there is only 1 car in the household (α_{iF}^C is more negative in the 1-car sample than in the 2-cars sample or in the whole sample while the values of time β_{iF}^j in each subsample are close). The intercept is positive (resp. negative) for the men in 2-cars (resp. 1-car) households. This means that, if both commuting times were zero, the reference man would rather commute by car in 2-cars households, but he would rather commute by bus in 1-car households. The coefficients of Workplace in Inner and Outer Ring in α_{iG}^C are all (i.e. for both genders and whatever the number of cars) positive, and they are larger for the Outer Ring than for the Inner Ring. This means that, compared to the reference (workplace inside Paris), for a zero commuting time, the probability to commute by car is larger when the individual works in the inner ring, and even larger when s/he works in the outer ring. This is consistent with the fact that it is very difficult and costly to park inside Paris and, to a less extent in the inner ring.

	Pooled sample		At least 2 cars		Only 1 car	
	Female	Male	Female	Male	Female	Male
Fixed utility of commuting by car α_{iG}^C						
Intercept (drive)	-1.839***	-0.772***	-0.340***	0.492***	-2.384***	-0.962***
x (workplace in Inner Ring)	2.200***	1.662***	2.243***	1.649***	1.958***	1.485***
x (workplace in Outer Ring)	2.871***	2.270***	2.923***	2.347***	2.573***	1.984***
x (occup="blue collar")	-0.040	0.397***	-0.306*	0.283**	0.166	0.374***
x (occup=employee)	-	-	-	-	-	-
x (occup="professional")	0.509***	0.377***	0.421***	0.208	0.341***	0.278***
x (occup="white collar")	0.467***	0.146**	0.345***	0.133	0.194**	-0.339***
x (occup="self-employed")	2.195***	2.090***	1.948***	1.887***	1.916***	1.770***
x Foreign	-0.822***	-0.403***	-1.057***	-0.545***	-0.553***	-0.212***
x # children aged 0-3	0.086***	n.s	0.115*	n.s	0.124***	n.s
x # children aged 4-6	0.131***	n.s	0.210***	n.s	0.092**	n.s
x # children aged 7-11	0.189***	n.s	0.103**	n.s	0.151***	n.s
x # children aged 12-16	0.199***	n.s	0.215***	n.s	0.136***	n.s
Value of time, by mode β_{iG}^j						
By transit, ref.	1.492***	1.186***	1.421***	1.634***	1.233***	0.749***
By car, ref.	2.446***	1.831***	3.006***	2.734***	2.147***	1.505***
<i>Ratio VOT Car/Transit, Ref.</i>	<i>1.639</i>	<i>1.543</i>	<i>2.116</i>	<i>1.673</i>	<i>1.741</i>	<i>2.009</i>
x (age-40)/10	0.223***	0.007	-0.276***	-0.422***	0.057	-0.060
x (occup="blue collar")	-0.599***	-0.387**	-0.460	-0.851***	-0.603***	-0.075
x (occup=employee)	-	-	-	-	-	-
x (occup="professional")	0.149	-0.152	0.184	-0.361	0.130	-0.002
x (occup="white collar")	0.549***	0.859***	0.760***	0.385	0.264	1.238***
x (occup="self-employed")	-1.096***	-0.468	-1.300***	-0.622	-0.139	-0.047
# observations	34915	34915	18377	18377	16538	16538
Log-likelihood	-16315	-15822	-5595	-5242	-8279	-9192
Pseudo-R² (by gender)	32.6%	34.6%	56.1%	58.9%	27.8%	19.8%
Pseudo-R² (F-M average)	33.6%		57.5%		23.8%	

Table 4: Estimation results for the Independent Binary Logit Mode choice
Significant at: *** 1% level; ** 5% level; * 10% level

Compared to the reference (employee) and for a zero commuting time, the probability to commute by car is larger for a man when he works as a blue collar. This may reflect the fact that factories are typically located in low density areas, which are less accessible than offices by public transportation. The difference between blue collars and employees is not significant for women (significant at the 10% level in the 2-car sample), but this may mainly result from the small number of blue collar women. Compared to the reference (employee), for a zero commuting time, the probability to commute by car is larger when the individual is professional, white-collar or self-employed, for both genders, except for white collar men in 1-car households. This exception can hardly be explained. The other effects may reflect the fact that, compared to employees, such jobs require more flexibility with respect to schedules and the car offers the possibility to travel somewhere else than the workplace.

The coefficients of the Foreign dummy in α_{iG}^C are all negative (both for men and women, and whatever the number of cars). This means that foreigners have a lower probability to commute by car than French commuters. This may reflect the fact that Foreigners (usually poorer than French commuters, even after controlling for occupation) are more sensitive than French commuters to the financial constraints which restrain the use of a car.

For the women, the fixed benefit of commuting by car increases with the number of children (by age group) in the couple. This result is consistent with the fact that, in Paris region, it is more common for the mother than for the father to drop the children to school or to other activities on the way to workplace. In the pooled sample, older children increase the benefit of commuting by car more than younger children. However, in the subsamples (1 or 2+ cars), the differences by children's age are not significant, and their order is sometimes (but not significantly) reversed.

4.2.2. Value of Time by mode and mode choice

The estimated value of time β_{iG}^j depends on gender, mode and individual characteristics (age and occupation). The specification used here also imposes that, for a given gender, the difference of VOT between the two modes (proportional to $\beta_{iG}^C - \beta_{iG}^B$) does not depend on individual characteristics or, equivalently, that the effect of individual characteristics on VOT is the same by car and by bus, i.e. that $\beta_{iG}^C - \beta_{i'G}^C = \beta_{iG}^B - \beta_{i'G}^B$ for any individuals i and i' .

For measuring the VOT, the reference individual is a 40-year old employee. Preliminary results, not reported here, showed no effect of nationality or number of children on the VOT.

The VOT is significantly larger (about twice for of the reference individual) for private transportation than for public transportation. Age has an ambiguous effect on the VOT: positive for both genders in the pooled sample (significant only for men), negative for both genders, as expected, in the 2-car sample, not significant for either gender in the 1-car sample. The VOT is larger for white collars and lower for blue-collars and self-employed, than in the employee reference category. The VOT in the professional category is never (i.e. whatever gender and number of cars) significantly different from the VOT of employees. Overall, several results appear surprising, as discussed in Section 4.3.

To translate the estimated coefficients β_{iG}^j into VOT expressed in euros per hour, we use the the 12.6 €/h official value in Paris area recommended by Quinet (2014). If we assume that the VOT of the reference individual commuting by car is 12.6 €/h, then all coefficients should be multiplied by $12.6/2.446=5.15$ for women in the pooled sample. As a result, according to the pooled sample estimates, the VOT of a white collar woman commuting by car would be $12.6*(2.446+0.549)/2.446=15.43$ €/h, whereas the VOT of a blue collar woman commuting by car would be $12.6*(2.446-0.599)/2.446=9.51$ €/h.

To help interpreting the values of the coefficients, we represent in Figure 2 the probability of commuting by car as a function of the common commuting time (assumed identical by transit and by car in this illustrative interpretation), for an individual in the reference category both for the fixed part and for the marginal part of the utility (French, 40-year old, employee,

without children, working in Paris). Three samples are displayed for each gender: 1 car, 2 or more cars and pooled sample. Since the VOT by car is larger than the VOT by transit (and constant), all probabilities decrease with commuting time. In each of the 3 samples, the probability of using the car is larger for the man than for the woman. When a couple acquires a second car, the probability to commute by car rises for each spouse and more substantially for the woman than for the man. For example, when the commuting time tends to zero, this probability to commute by car is more than 4 times larger with 2 cars than with 1 car for the woman, whereas it is only multiplied by 2 for the man. This confirms the result of Moses and Williamson (1963) that the man has priority to use the first car, whereas the second car is mainly for the woman.

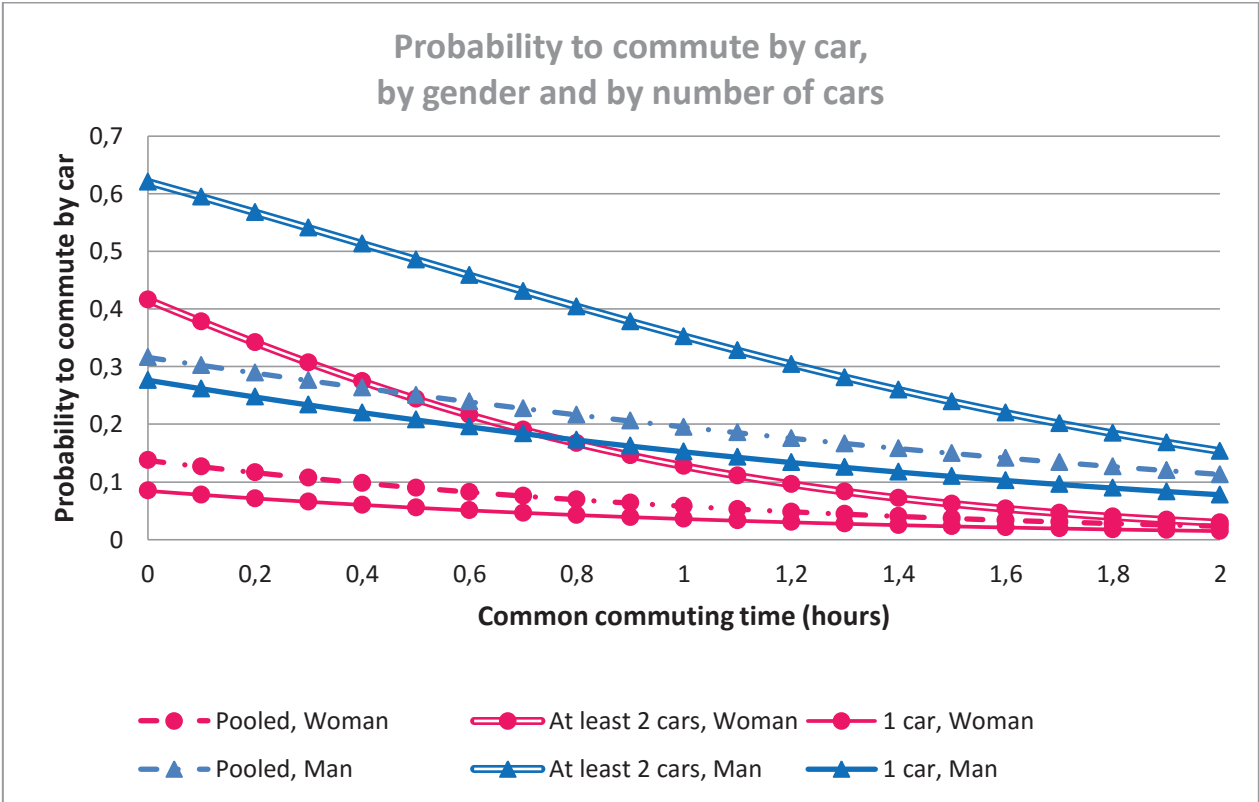

Figure 2: Probability to commute by car, as a function of common commuting time. Independent choices model.

4.3. Criticism and suggested solution

Some counter-intuitive results displayed in Table 4 are discussed below.

The ratio of the VOT by mode (car/bus) is larger for women than for men when there are at least 2 cars in the household ($2.116 > 1.673$), but the same ratio is smaller for women than for men in the households with only 1 car ($1.741 < 2.009$). In addition, the fixed utilities strongly depend on the number of cars, which is implicitly assumed to be exogenous in this section. Consistently with all these results, the probability to commute by car strongly increases with the number of cars in the households (see Figure 2), as expected.

Imposing that preferences do not depend on the number of cars (pooled sample) reduces the log-likelihood by $16,315 - (5,595 + 8,279) = 2,241$ for women and by $15,822 - (5,252 + 9,192) = 1,378$ for men, that is a total of $2,241 + 1,378 = 3,819$ for the couple. Such huge differences

cannot be explained by a change in preferences when a second car is bought. It seems more plausible that these differences mainly reflect constraints (both spouses cannot commute by car when there is only one car), as discussed in Section 5. An additional explanation, related to the endogeneity of car ownership, is also produced in Section 6.

The explanatory power of the model, as measured by the pseudo-R² (Mc Fadden's Likelihood Ratio Index) is fair in the 2-car sample, but very low in the 1-car sample, especially for the men (less than 20%). This is partly because the choice set is not well specified for one of the spouses when there is only one car since they cannot use it both if they do not go in the same direction. Once again, this suggests that the decisions of the two spouses are interrelated and should be treated as a joint choice within the same model.

In the next Section, we explore the relevance of this explanation. To do this, we expand the model by considering that spouses' mode choice decisions are interdependent. For this purpose, we need to generalize the standard logit individual choice model to joint decisions.

5. Joint Multinomial Logit

5.1. A MNL model with different choice sets

We consider here the joint decision of the two members of a couple and assume that they maximize the weighted utility of spouses. These weights represent the respective importance of the decision makers (each spouse).

We consider the two cases below: (1) there is a single car in the household and (2) there are two or more cars in the household (when there is no car, the mode choice solution is straightforward: both spouses are constrained to commute by public transport).

If there is one car in the household, the five different options are: (B, B) if both spouses commute by bus, (C^A, B) if the woman drives alone while the man commutes by bus, (B, C^A) if the man drives alone while the woman commutes by bus, (C^D, C^P) if both spouses commute by car and the woman drives and (C^P, C^D) if both spouses commute by car and the man drives.

If there are two or more cars in the household, the different choices are the same as above, plus a sixth additional option: (C^A, C^A) , which corresponds to the case where both spouses drive alone. Note that since here we consider joint decisions, the alternative "car" is now split in three alternatives: C^A , C^D and C^P .

Depending on the number of cars, the couple choice set, Ω , is equal to:

$$\Omega_1 = \{(B, B), (C^A, B), (B, C^A), (C^D, C^P), (C^P, C^D)\} \text{ for a 1-car household}$$

$$\Omega_2 = \{(B, B), (C^A, B), (B, C^A), (C^D, C^P), (C^P, C^D), (C^A, C^A)\} \text{ for a 2-car household.}$$

Contrarily to the standard individual mode choice model, alternatives here encapsulate the choice of the man and the woman. Whatever the number of cars, spouses decisions are still

independent in the (B, B) case, but dependent in the cases of, (C^D, C^P) and (C^P, C^D) . When there is one car, the alternatives (C^A, B) , (B, C^A) also involve dependent decisions.

The indirect utility function associated to alternative $(j, j') \in \Omega$ is given by:

$$U_i^{j,j'} = V_i^{j,j'} + \varepsilon_i^{j,j'}, (j, j') \in \Omega. \quad (4)$$

The random terms $\varepsilon_i^{j,j'}$ are associated to the couple joint choice (j, j') . We postulate that the deterministic utility of the couple is a weighted sum of the deterministic utility of the spouses:

$$V_i^{j,j'} = \lambda_i V_{iF}^j + (1 - \lambda_i) V_{iM}^{j'}, (j, j') \in \Omega, \quad 0 \leq \lambda_i \leq 1. \quad (5)$$

The weight λ_i of the woman's utility represents her Pareto weight (and $(1 - \lambda_i)$ is the Pareto weight of the man), as discussed below in Section 5.2. They may or may not be assumed to vary across households. Consistently with Section 2, the unitary model corresponds to the case where Pareto weights are constant and exogenous, whereas the collective model corresponds to the case where Pareto weights vary endogenously across households.

The deterministic individual utilities V_{iF}^j and $V_{iM}^{j'}$ are specified in Equation (2). The constant terms α_{iF}^j and $\alpha_{iM}^{j'}$, as well as the VOT β_{iF}^j and $\beta_{iM}^{j'}$ are now specific to the 4 cases: B , C^A , C^D , and C^P . By contrast, the travel time is the same when one spouse drives the car alone and when s/he is driven to his/her work place by the other spouse, so we have the logical relation: $tt_{iG}^{C^A} = tt_{iG}^{C^P} = tt_{iG}^C$, where tt_{iG}^C was defined in Section 4. When a driver G drops his/her spouse G' , s/he incurs first the travel time from home to the workplace of his/her spouse G' : $tt_{iG'}^C$ (while they are together in the car), and then the travel time from the workplace of G' to his/her own workplace: $tt_{iG'G}^C$ (alone). This represents a detour compared to the direct trip of the driver from home to work, since the triangular inequality implies that $tt_{iG'}^C + tt_{iG'G}^C \geq tt_{iG}^C$.

In order to obtain expressions valid for all modes, we define the travel time $tt_{iG}^{C^D}$ of commuting with mode C^D as follows:

$$\beta_{iG}^{C^D} \cdot tt_{iG}^{C^D} = \beta_{iG}^{C^D} \cdot tt_{iG'}^C + \beta_{iG}^{C^A} \cdot tt_{iG'G}^C, G \neq G', G, G' = M, F. \quad (6)$$

With this definition, the deterministic individual utilities are, for all the modes j , given by:

$$V_{iG}^j = \alpha_{iG}^j - \beta_{iG}^j \cdot tt_{iG}^j, j = B, C^A, C^D, C^P, G = M, F. \quad (7)$$

Note that when the spouses share the same car, part of the trip is "together" and the driver incurs an additional travel time "alone". In the other cases, spouses only incur a travel time "alone". In both cases, the couple utility is of the form:

$$V_i^{j,j'} = \alpha_i^{j,j'} - \lambda_i \cdot \beta_{iF}^j \cdot tt_{iF,alone}^j - (1 - \lambda_i) \cdot \beta_{iM}^{j'} \cdot tt_{iM,alone}^{j'} - \beta_i^{j,j'} \cdot tt_{iFM,together}^{j,j'}, (j, j') \in \Omega, \quad (8)$$

where the couple's fixed benefit of commuting by joint mode $(j, j') \in \Omega$ and where the VOT of travelling together :

$$\alpha_i^{j,j'} = \lambda_i \cdot \alpha_{iF}^j + (1 - \lambda_i) \cdot \alpha_{iM}^{j'} \text{ and } \beta_i^{j,j'} = \lambda_i \cdot \beta_{iF}^j + (1 - \lambda_i) \cdot \beta_{iM}^{j'}, (j, j') \in \Omega \quad (9)$$

are defined in Table 5 below.

Individual-specific		Identifiability	Couple-specific	
Female	Male			
α_{iF}^B	α_{iM}^B	Normalized	$\alpha_i^{B,B}$	$= \lambda_i \cdot \alpha_{iF}^B + (1 - \lambda_i) \cdot \alpha_{iM}^B$
β_{iF}^B	β_{iM}^B	Identified separately		$\beta_{iF}^B ; \beta_{iM}^B$
$\alpha_{iF}^{C^A}$	α_{iM}^B	Identified separately	$\alpha_i^{C^A,B}$	$= \lambda_i \cdot \alpha_{iF}^{C^A} + (1 - \lambda_i) \cdot \alpha_{iM}^B$
α_{iF}^B	$\alpha_{iM}^{C^A}$	Identified separately	α_i^{B,C^A}	$= \lambda_i \cdot \alpha_{iF}^B + (1 - \lambda_i) \cdot \alpha_{iM}^{C^A}$
$\beta_{iF}^{C^A}$	$\beta_{iM}^{C^A}$	Identified separately		$\beta_{iF}^{C^A} ; \beta_{iM}^{C^A}$
		Constrained	$\alpha_i^{C^A,C^A}$	$= \lambda_i \cdot \alpha_{iF}^{C^A} + (1 - \lambda_i) \cdot \alpha_{iM}^{C^A}$
$\alpha_{iF}^{C^P}$	$\alpha_{iM}^{C^D}$	Hardly identified separately	$\alpha_i^{C^D,C^P}$	$= \lambda_i \cdot \alpha_{iF}^{C^D} + (1 - \lambda_i) \cdot \alpha_{iM}^{C^P}$
$\alpha_{iF}^{C^D}$	$\alpha_{iM}^{C^P}$	Hardly identified separately	$\alpha_i^{C^P,C^D}$	$= \lambda_i \cdot \alpha_{iF}^{C^P} + (1 - \lambda_i) \cdot \alpha_{iM}^{C^D}$
$\beta_{iF}^{C^P}$	$\beta_{iM}^{C^D}$	Hardly identified separately	$\beta_i^{C^D,C^P}$	$= \lambda_i \cdot \beta_{iF}^{C^D} + (1 - \lambda_i) \cdot \beta_{iM}^{C^P}$
$\beta_{iF}^{C^D}$	$\beta_{iM}^{C^P}$	Hardly identified separately	$\beta_i^{C^P,C^D}$	$= \lambda_i \cdot \beta_{iF}^{C^P} + (1 - \lambda_i) \cdot \beta_{iM}^{C^D}$

Table 5 : Definition and identification of (α, β) parameters

In Equation (8), the travel time $tt_{iG,alone}^k \in \{tt_{iG}^C, tt_{iG}^B\}$ corresponds to the time spent alone and $tt_{iFM,together}^{j,j'} \in \{tt_{iF}^C, tt_{iM}^C\}, (j, j') \in \{(C^D, C^P), (C^P, C^D)\}$ corresponds to the time spent together in the same car from household to the workplace of the spouse passenger.

Assuming that the error terms are i.i.d. standard Gumbel, the choice probabilities are given by the Multinomial Logit formula:

$$P_i(j, j') = \frac{\exp(V_i^{j,j'})}{\sum_{(k,k') \in \Omega} \exp(V_i^{k,k'})}, (j, j') \in \Omega \quad (10)$$

The intercept of the utility of travelling together (that is the average of the man's and the woman's fixed utilities) can hardly be split into the gender-specific intercepts. Similarly, the coefficient of the commuting time together ($\beta_{iF}^{C^P}$, $\beta_{iM}^{C^D}$, $\beta_{iF}^{C^D}$ and $\beta_{iM}^{C^P}$) can hardly be estimated separately for the man and the woman of each couple since this common commuting time is the same for both spouse.

5.2. Estimation results with equal Pareto weight (or unitary model)

Table 6 presents the estimations of the joint models in the unitary case, when spouses' weights are assumed exogenous and constant across households (and normalized to 0.5 for

each spouse). As previously, we compare the estimates for the households with one car, with two (or more) cars, and in the pooled sample (one or two or more cars).

The sign and significance of the coefficients are rather unchanged compared to the independent model (Table 4). A notable exception concerns the fixed utility of the reference man in 2-car households when driving alone: it has the same negative sign (although insignificant for man in 2-car households) whatever the number of cars, unlike in the independent model.

As in Section 4, households with no car are excluded from the estimation sample since, in such households, the choice set of each spouse is reduced to a single alternative. Compared to the estimations of the independent binary model (see Table 4), the joint model exhibits more realistic results for the parameters already estimated and reported in Table 4, and discussed in Section 4.3, even when Pareto weights are assumed constant (Table 6), as explained below.

The ratio of VOT by mode is more consistent across samples by number of cars for the men (1.614, 1.742 and 1.754 instead of 1.543, 1.673 and 2.009), and this ratio is now consistently larger for women than for men in the 3 samples. However, this ratio still varies across samples for women (1.878, 2.206 and 1.922, respectively), although this variation is more moderate than in Table 4 (1.639, 2.116 and 1.741, respectively).

Imposing that preferences do not change when a second car is bought by the household now reduces the log-likelihood by $11,434 - 10,644 + 18,020 - 17,135 = 1,675$. This is less than half the difference estimated for the independent mode choice model of Section 4 (3,819), this means that preferences still significantly differ across samples, when the number of cars in the household increases.

Additional parameters are estimated in this joint mode choice model. When spouses travel together by car, this induces an extra fixed premium for commuting together, as well as an additional VOT for commuting together. The fixed premium for commuting together adds to the average intercept for commuting alone by car for each spouse, weighted by the spouses' respective Pareto weights (which are normalized to 0.5 for each spouse here). It corresponds to the difference between the average fixed utility of travelling by car together and the average of man's and woman's fixed utility of driving alone:

$$\alpha_i^{j,j'} - \alpha_i^{C^A, C^A} = [\lambda_i \cdot \alpha_{iF}^j + (1 - \lambda_i) \cdot \alpha_{iM}^{j'}] - [\lambda_i \cdot \alpha_{iF}^{C^A} + (1 - \lambda_i) \cdot \alpha_{iM}^{C^A}] = 0.5 \cdot [(\alpha_{iF}^j - \alpha_{iF}^{C^A}) + (\alpha_{iM}^{j'} - \alpha_{iM}^{C^A})] \quad (11)$$

Similarly, the additional VOT for commuting together adds to the average VOT for commuting alone by car for each spouse, weighted by the spouses' respective Pareto weights:

$$\beta_i^{j,j'} - \beta_i^{C^A, C^A} = [\lambda_i \cdot \beta_{iF}^j + (1 - \lambda_i) \cdot \beta_{iM}^{j'}] - [\lambda_i \cdot \beta_{iF}^{C^A} + (1 - \lambda_i) \cdot \beta_{iM}^{C^A}] = 0.5 \cdot [(\beta_{iF}^j - \beta_{iF}^{C^A}) + (\beta_{iM}^{j'} - \beta_{iM}^{C^A})] \quad (12)$$

The value of these two parameters may depend on who is driving.

Mode choice	Pooled sample		at least 2 cars		1 car	
	woman	man	Woman	man	woman	Man
Fixed utility of commuting by car alone $\alpha_{iG}^{C^A}$						
Intercept (drive alone)	-2.986***	-1.091***	-2.136***	-0.134	-4.621***	-2.004***
x (workplace in Inner Ring)	4.307***	3.247***	4.579***	3.269***	4.055***	2.983***
x (workplace in Outer Ring)	5.551***	4.381***	5.920***	4.652***	5.224***	3.907***
x (occup="blue collar")	-0.065	0.701***	-0.780***	0.371	0.265	0.773***
x (occup="employee")	-	-	-	-	-	-
x (occup="professional")	0.918***	0.718***	0.938***	0.273	0.702***	0.700***
x (occup="white collar")	0.847***	0.394***	0.885***	0.318	0.449**	-0.162
x (occup="self-employed")	3.941***	4.053***	3.579***	3.783***	3.529***	3.729***
x Foreign	-1.559***	-0.765***	-2.124***	-0.936***	-1.148***	-0.448***
x # children aged 0-3	0.191***	n.s	0.303**	n.s	0.226***	n.s
x # children aged 4-6	0.244***	n.s	0.466***	n.s	0.163*	n.s
x # children aged 7-11	0.311***	n.s	0.212**	n.s	0.285***	n.s
x # children aged 12-16	0.344***	n.s	0.431***	n.s	0.244***	n.s
Fixed premium for commuting together $\alpha_i^{j,j'} - \alpha_i^{C^A,C^A}$						
when man drives	-1.129***		0.024		-0.367***	
when woman drives	0.003		-0.108		0.442***	
Value of time, by mode β_{iG}^j						
by transit	2.811***	2.720***	2.758***	2.894***	2.471***	2.277***
by car, alone	5.280***	4.390***	6.085***	5.041***	4.749***	3.993***
<i>Ratio VOT Car/Bus</i>	1.878	1.614	2.206	1.742	1.922	1.754
Additional VOT for commuting together $\beta_i^{j,j'} - \beta_i^{C^A,C^A}$						
when man drives	-1.988***		-1.270***		-1.850***	
when woman drives	14.676***		-0.861**		10.624***	
x (age-40)/10	0.059	-0.276***	-0.610***	-0.758***	-0.093	-0.295***
x (occup="blue collar")	-1.139***	-0.638**	-0.857*	-1.381***	-1.202***	-0.271
x (occup="employee")	-	-	-	-	-	-
x (occup="professional")	0.422*	-0.499*	0.367	-0.353	0.508	-0.516*
x (occup="white collar")	1.361***	1.150***	1.611***	0.702	1.151**	1.327***
x (occup="self-employed")	-1.977**	-1.856***	-2.697***	-2.017***	-0.291	-1.395***
Woman's bargaining power						
	0.500		0.500		0.500	
2+ cars						
# observations	18377		18377		-	
Log-likelihood	-11434		-10644		-	
Pseudo-R²	36.1%		40.5%		-	
1 car						
# observations	16538		-		16538	
Log-likelihood	-18020		-		-17135	
Pseudo-R²	25.3%		-		28.9%	

Table 6: Estimation results for the joint multinomial logit with constant Pareto weights (unitary model)

Significant at: *** 1% level; ** 5% level; * 10% level

Our estimates show that the fixed premium for commuting together is not significantly different from zero when there are at least 2 cars in the household, whoever is driving, whereas, for households with 1 car only, it is significantly positive when the woman drives and negative when the man drives. It is also significantly negative in the pooled sample when the man drives. The average VOT of the couple is significantly reduced when they commute

together rather than alone and the man drives. This suggests that the time spent to travel by car is less burdensome when spouses are together than when they are alone, at least when the man drives. When the woman drives, the VOT is also reduced in the 2-car sample, but increased to extremely large values and unrealistic values in the 1-car sample and in the pooled sample. Such differences across samples can hardly be explained and will be discussed below.

Altogether, it means that, in the 2-car sample, if travelling together would not induce a detour, spouses would prefer commuting together rather than commuting alone, especially if the man drives.

The values of coefficients cannot be interpreted directly because parameters are identified only up to a multiplicative constant, which is different across samples (the variance of the residuals is normalized to $\pi^2/6$ in each sample). In order to ease the interpretation of results of Table 6, we represent in Figure 3 and Figure 4 the probabilities that both spouses commute by car as a function of the common (identical for man and woman) commuting time, for individuals in the reference category both for the fixed part and for the marginal part of the utility, according to the estimates of Section 5.2.

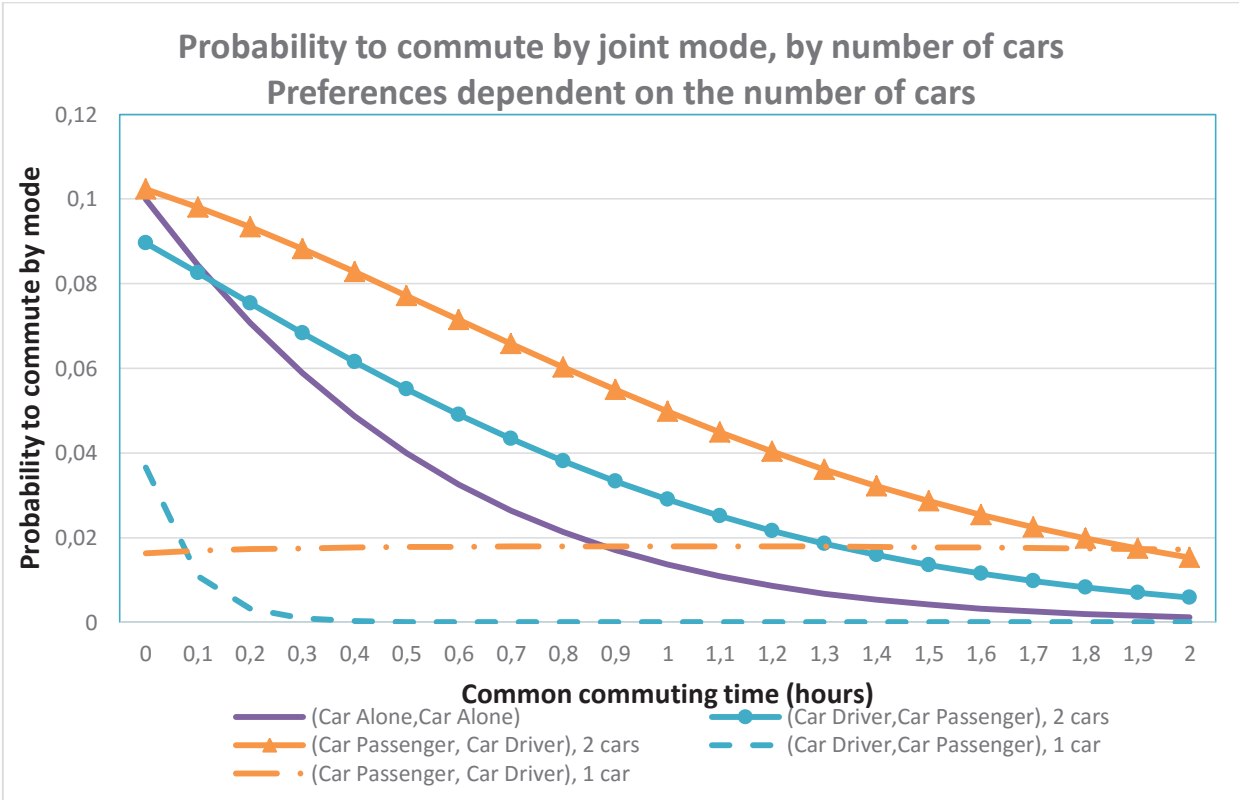

Figure 3: Probability to commute by car alone and together, as a function of commuting time in hours (same workplace for both spouses). Joint model with Pareto weight=0.5. Preferences dependent on the number of cars.

Figure 3 uses the coefficients estimated separately in the subsample of households with 1 car and in the subsample of households with at least 2 cars, whereas Figure 4 uses the coefficients estimated in the pooled sample, imposing identical preferences for households with only 1 car or with at least 2 cars.

In this purely illustrative example, man and woman are assumed to work in the same place, so that there is no detour when spouses commute together, and the commuting time is assumed the same by car and by public transportation.

For 1-car and 2-car households, two probabilities are represented: the probability to drive together when the woman drives and when the man drives. For household with 2 cars, an additional probability is represented: the probability that each spouse commutes alone by car. This probability decreases less and less rapidly as the commuting time increases, on both figures.

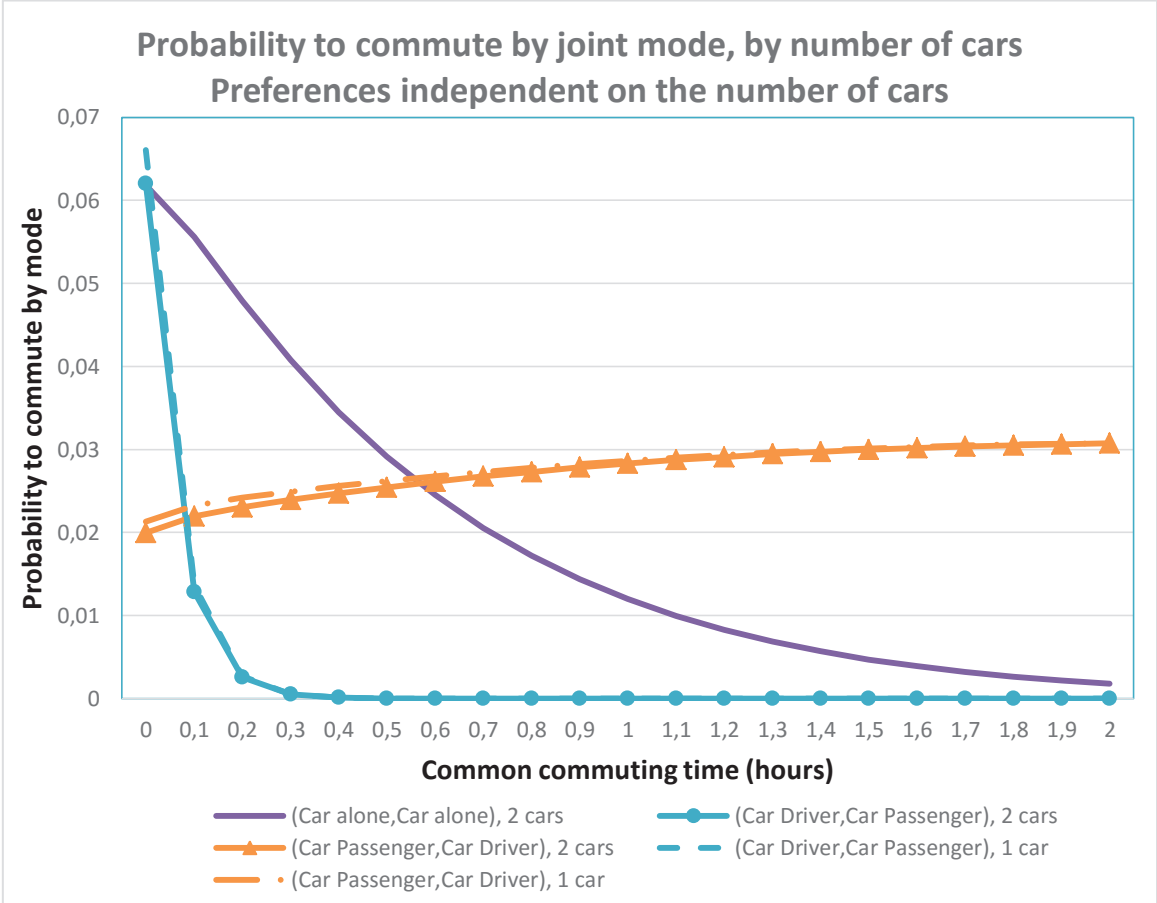

Figure 4: Probability to commute by car alone and together, as a function of common commuting time in hours (same workplace for both spouses). Joint model with Pareto weight=0.5. Preferences independent on the number of cars.

In the pooled sample (i.e. when preferences are assumed independent on the number of cars), the probability that the woman drops the man to his workplace exceeds 6% for very short distances, and it very rapidly tends to zero (as soon as the commuting time exceeds 15 minutes). By contrast, the probability that the man drops the woman to her workplace slightly increases with commuting time.

Results are fundamentally different when preferences are allowed to differ as a function of the number of cars. In this case, the probability that either spouse drops the other is almost always less than 2% with 1 car (2% to 4% for travel times less than 5 minutes if the woman drives), whereas it goes to 9% or 10% for very small commuting times in households with 2 cars.

Such differences in spouses' preferences in households with 1 and 2 cars are hard to explain. They imply that either preferences change when a second car is bought, or an endogenous sample selection bias is induced by the fact that households decide car ownership. An alternative explanation could be related to the heterogeneity of Pareto weights across households. We will see in Section 5.3 that, although Pareto weights significantly differ across households, this is not enough to explain the surprising results obtained in Section 5.2.

5.3. Estimation results with spouse-specific Pareto weights (or collective model)

One potential reason for the unexplained differences found in Section 5.2 is the possibility that the Pareto weight varies across households, as a function of each spouse's characteristics such as age, nationality, education or type of job contract, and of couple's characteristics such as number of children or tenure status. The results of the corresponding model are reported in Table 7.

To ensure that woman's Pareto weight λ_i is comprised in $[0, 1]$, it is assumed to be a logistic function of both spouses' characteristics and household characteristics $\lambda_i = \frac{\exp(X_i \cdot \gamma)}{1 + \exp(X_i \cdot \gamma)}$, where X_i denotes a vector of individual and couple-specific determinants of the Pareto weight.

We consider no intercept in this function, which amounts to normalize to 0.5 the Pareto weight in the reference couple, i.e. to consider that the woman and the man in the reference couple have equal Pareto weights (50%). This reference couple is composed of French tenants, without children, with equal age and both with a permanent working contract. The results are reported in Table 7 and are qualitatively similar to that of Table 6 in Section 5.2.

The fixed premium for commuting together is similar to the one found in Section 5.2, as well as the additional VOT for commuting together when the man drives. By contrast, the additional VOT for commuting together when the woman drives, becomes unexpectedly large in the pooled sample and in the sub-sample of 1-car households.

According to our estimates, the woman's Pareto weight tends to increase when she is older than her husband, but this effect is not significant. Foreign women have a larger Pareto weight when both spouses are Foreigners than when both spouses are French, although this difference is not significant in the 2-car sample.

Compared to a situation in which neither spouse has a temporary job contract, the woman's Pareto weight is significantly increased when only her husband has a temporary contract, and it is marginally decreased when she is the only one with a temporary contract, although this effect is significant only in the pooled sample. Finally, the woman's Pareto weight is significantly increased in households which own their dwelling, and marginally (not significantly) decreased when the number of children increases.

Mode choice	Pooled sample		at least 2 cars		1 car	
	woman	man	woman	man	woman	man
	Fixed utility of commuting by car alone $\alpha_{iG}^{C^A}$					
Intercept(drive alone)	-2.825***	-1.144***	-2.041***	-0.154	-4.424***	-2.067***
x (workplace in Inner Ring)	4.156***	3.388***	4.498***	3.349***	3.922***	3.130***
x (workplace in Outer Ring)	5.332***	4.586***	5.785***	4.780***	5.033***	4.112***
x (occup="blue collar")	-0.027	0.715***	-0.753***	0.429	0.278	0.800***
x (occup="employee")	-	-	-	-	-	-
x (occup="professional")	0.875***	0.743***	0.911***	0.301	0.697***	0.722***
x (occup="white collar")	0.804***	0.398***	0.867***	0.337	0.448**	-0.185
x (occup="self-employed")	3.864***	4.205***	3.443***	3.874***	3.441***	3.854***
x foreign	-1.562***	-0.693**	-2.121***	-0.890**	-1.047**	-0.398**
x # children aged 0-3	0.194***	n.s	0.314**	n.s	0.206**	n.s
x # children aged 4-6	0.252***	n.s	0.459***	n.s	0.142	n.s
x # children aged 7-11	0.318***	n.s	0.219**	n.s	0.271***	n.s
x # children aged 12-16	0.353***	n.s	0.435***	n.s	0.235***	n.s
	Fixed premium for commuting together $\alpha_i^{j,j'} - \alpha_i^{C^A,C^A}$					
when man drives	-1.143***		-0.012		-0.382***	
when woman drives	-0.004		-0.153		0.438***	
	Value of time, by mode β_{iG}^j					
By transit	2.679***	2.811***	2.684***	3.031***	2.379***	2.354***
By car, alone	5.091***	4.553***	5.987***	5.206***	4.580***	4.174***
Ratio VOT Car/Bus	1.900	1.620	2.231	1.717	1.925	1.773
	Additional VOT for commuting together $\beta_i^{j,j'} - \beta_i^{C^A,C^A}$					
when man drives	-2.008***		-1.185***		-1.860***	
when woman drives	15.019***		-1.117***		11.087***	
x (age-40)/10	-0.028	-0.231***	-0.634***	-0.766***	-0.121	-0.295***
x (occup="blue collar")	-1.098***	-0.614**	-0.802*	-1.528***	-1.136***	-0.258
x (occup="employee")	-	-	-	-	-	-
x (occup="professional")	0.379	-0.485*	0.388	-0.439	0.420	-0.548*
x (occup="white collar")	1.272***	1.267***	1.547***	0.677	1.053**	1.410***
x (occup="self-employed")	-2.126***	-1.907***	-2.588***	-2.253***	-0.282	-1.431***
	Woman's Pareto weight					
x (woman's age-man's age)/10	0.039		0.077		0.024	
x (both spouses are French)	-		-		-	
x (both spouses are foreign)	0.221***		0.170		0.261***	
x (foreign woman & French man)	0.129		-0.281*		-0.024	
x (French woman & foreign man)	-0.007		-0.129		0.160	
x (tenure status=homeownership)	0.178***		0.102*		0.157***	
x (neither spouse has temporary contract)	-		-		-	
x (both spouses have temporary contract)	0.047		0.172		0.138	
x (only woman has temporary contract)	-0.130***		-0.062		-0.093	
x (only man has temporary contract)	0.358***		0.429***		0.497***	
x # children	-0.033**		-0.026		-0.024	
# observations	18377		18377		-	
log-likelihood	-11412		-10632		-	
pseudo-R ²	36.2%		40.6%		-	
# observations	16538		-		16538	
log-likelihood	-17999		-		-17116	
pseudo-R ²	25.4%		-		29.0%	
# observations	34915		-		-	
log-likelihood	-29411		-		-	
pseudo-R ²	30.0%		-		-	

Table 7: Estimation results for the joint multinomial logit with couple-specific Pareto Weights
Significant at: *** 1% level; ** 5% level; * 10% level

5.4. Criticism and suggested solution

Table 8 compares the predictive power of the models estimated in Sections 4, 5.2 and 5.3, by comparing the observed percentage of households in which both spouses commute by car to its prediction, separately in households with 1 and 2 cars. It confirms that mode choice is a joint decision at the household level, in the sense that the probability that both spouses commute by car is better explained by a joint mode choice model at the couple level than by a model assuming independent mode choice by spouses, as it is often assumed in the literature. The predictive power of the joint model is only marginally improved when Pareto weights are assumed heterogeneous across households, as discussed below.

		Preferences independent on the number of cars (C ^P ,C ^D)(C ^D ,C ^P) Total				Preferences dependent on the number of cars (C ^A ,C ^A)(C ^P ,C ^D)(C ^D ,C ^P) Total			
All households	Observed	49.5%				49.5%			
	Independent model	46.3%				49.0%			
	Joint model : fixed PW	23.3%	18.8%	3.4%	45.5%	17.5%	22.9%	8.9%	49.4%
	variable PW	23.0%	19.3%	3.3%	45.6%	17.3%	23.6%	8.5%	49.4%
1-car households	Observed	21.8%				21.8%			
	Independent model	36.3%				22.5%			
	Joint model: fixed PW	0.0%	21.5%	3.9%	25.3%	0.0%	18.1%	3.7%	21.8%
	variable PW	0.0%	21.5%	3.9%	25.3%	0.0%	18.2%	3.6%	21.8%
2-car households	Observed	74.5%				74.5%			
	Independent model	55.4%				72.8%			
	Joint model: fixed PW	44.3%	16.4%	2.9%	63.6%	33.3%	27.2%	13.6%	74.2%
	variable PW	44.3%	16.4%	2.9%	63.6%	33.0%	28.4%	12.9%	74.2%

Table 8: Probability that both spouses commute by car, by model (* PW stands for Pareto weight)

The predictive power of the independent models is particularly poor under the realistic hypothesis that preferences do not change after a second car is bought (left-hand side of the table). Although the predictions of each model on the pooled sample (merging households with 1 car and those with 2 or more cars) are close under the assumption that preferences do not depend on the number of cars (46.3% for the independent model against 45.6% for the joint model with variable Pareto weight, compared to the observed 49.5%), both models overestimate the probability to commute by car for 1-car households and underestimate that of 2-car households. However, the joint model overestimates that of 1-car households by 3.5 percentage points (25.3%-21.8%) against 15 points for the independent model (36.3%-21.8%). Similarly, joint models underestimate the probability to commute by car in 2-car households by only 11 percentage points (74.5%-63.6%) against 19 for the independent model (74.5%-55.4%).

The predictive power of the independent model is significantly improved when it is assumed that preferences depend on the number of cars. In this case, the probability that both spouses commute by car fit observed fraction nearly as well those of the joint model (right hand side

of Table 8). However, this improvement relies on quite unrealistic difference across samples, as detailed below.

When preferences are assumed to depend on the number of cars, in 1-car households, the fixed premium for commuting together is significantly negative when the man drives and significantly positive when the woman drives whereas, in 2-car households, the fixed premium for commuting together is slightly negative but not significant whoever drives.

Furthermore, the additional VOT when the woman drives the man to work appears unrealistically large when the joint model is estimated on the pooled sample, as well as in the 1-car sample. By contrast, the additional VOT when the woman drives in 2-car households is significantly negative and the same as when the man drives.

These surprising results suggest that the number of cars owned by households does not only influence their mode choice through the determination of their choice set. Car ownership is also endogenous in the sense that the number of cars is chosen by households together with mobility decision: car ownership and mode choice are interrelated decisions determined by common observed and unobservable variables. To take account of such endogeneity, the choice of the number of cars is explicitly accounted for in the model developed in the next section.

6. Endogeneous car ownership and nested model

6.1. Car ownership and mode choice

We extend the previous multinomial joint mode choice model in order to model simultaneously couple's choices of travel mode and car ownership. We obtain a three-level nested model in which the lower level corresponds to the mode choice, the intermediate level corresponds to the choice of a second car (conditional on choosing to own at least one) and the upper level corresponds to the choice to own at least one car.

As shown by Figure 5, mode choice and car ownership are interrelated. When a household choose to own no car, its mode choice set is restricted to the alternative (B, B) (both spouses commute by public transport). When a household opts for car ownership, the choice of the number of cars determines the mode choice set as described in Section 5.

According to the properties of the i.i.d. Gumbel distribution, the maximum utility that a 1-car household i can expect given the mode choice decision is then given by the inclusive value:

$$I_i^{1Car} = \log \left[\exp(V_i^{B,B}) + \exp(V_i^{C^A,B}) + \exp(V_i^{B,C^A}) + \exp(V_i^{C^D,C^P}) + \exp(V_i^{C^P,C^D}) \right]. \quad (13)$$

The maximum utility that a 2-car household i can expect given the mode choice decision is given by another inclusive value:

$$I_i^{2Car} = \log \left[\exp(V_i^{B,B}) + \exp(V_i^{C^A,B}) + \exp(V_i^{B,C^A}) + \exp(V_i^{C^D,C^P}) + \exp(V_i^{C^P,C^D}) + \exp(V_i^{C^A,C^A}) \right]. \quad (14)$$

The inclusive value represents the ex-ante expected maximum utility and satisfies Roy's identity. In addition to the utility obtained from the mode choice, we assume that, conditionally on car ownership, owning n cars ($n \geq 1$) provides a household with an intrinsic deterministic utility denoted V_i^{nCar} . Conditionally on car ownership, the utility associated with n -car ownership ($n=1, 2$) can then be written:

$$V_i^{nCar} + \mu^{nCar} I_i^{nCar} + \varepsilon_i^{nCar}, \quad nCar=1, 2, \quad (15)$$

where μ^{nCar} denotes the coefficient of the inclusive value and ε_i^{nCar} is a (0,1) Gumbel-distributed error term.

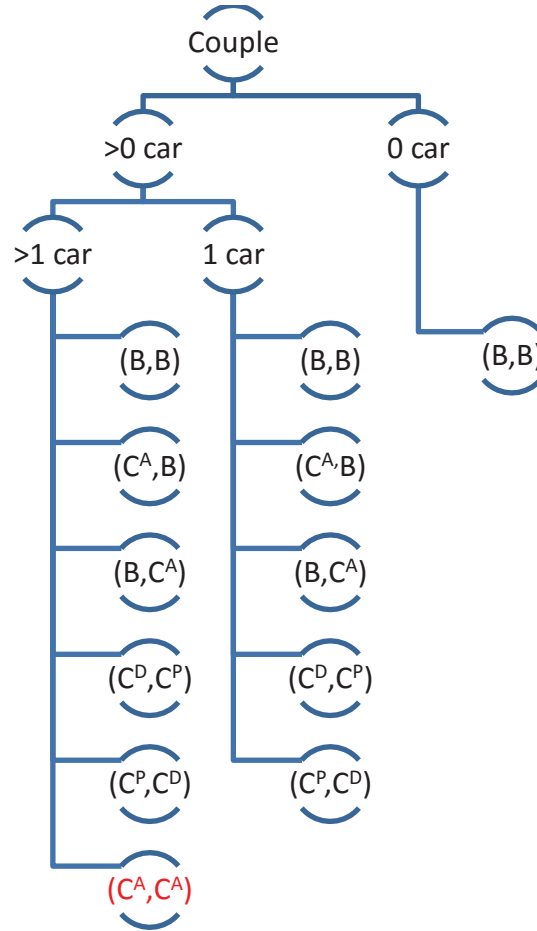

Figure 5: Nested structure of mode choice and car ownership

By normalizing the intrinsic utility V_i^{1Car} to zero, the probability to choose a second car can be written:

$$P_i^{2Car} = \frac{\exp(V_i^{2Car} + \mu^{2Car} I_i^{2Car})}{\exp(\mu^{1Car} I_i^{1Car}) + \exp(V_i^{2Car} + \mu^{2Car} I_i^{2Car})}. \quad (16)$$

Analogously, at the top level of the nested structure, the probability that the household choose to have at least one car is given by the following formula:

$$P_i^{Car} = \frac{\exp(V_i^{Car} + \mu^{Car} I_i^{Car})}{\exp(\mu^{noCar} I_i^{noCar}) + \exp(V_i^{Car} + \mu^{Car} I_i^{Car})}, \quad (17)$$

where V_i^{Car} designs the deterministic utility of owning at least one car (the deterministic utility of owning no car is normalized at zero) and the inclusive value I_i^{Car} (I_i^{noCar}) corresponds to the maximum utility that household i can obtain from mode choice when owning at least one car (no car):

$$I_i^{Car} = \log \left[\exp(\mu^{1Car} I_i^{1Car}) + \exp(V_i^{2Car} + \mu^{2Car} I_i^{2Car}) \right],$$

$$I_i^{noCar} = \log \left[\exp(V_i^{B,B}) \right] = V_i^{B,B}.$$

To sum up, the probability that household i chooses the mode (j, j') and owns n cars ($n=1,2$) is the product:

$$P_i^n(j, j') = P_i(n) \times P_i(j, j' | n),$$

where mode choice probabilities $P_i(j, j' | n)$, $n=1,2$, are defined in Section 5 (see Equation (10)) and:

$$P_i(1) = P_i^{1Car} \times P_i^{Car},$$

$$P_i(2) = P_i^{2Car} \times P_i^{Car}.$$

The probability that a household does not own a car and, consequently, that both spouses commute by public transport is given by:

$$P_i^0(B, B) = P_i^{noCar} = (1 - P_i^{1Car} - P_i^{2Car}).$$

We postulate that the deterministic utilities V_i^{2Car} and V_i^{Car} are weighted averages of the man's and woman's utilities. The Pareto weights are assumed to be the same as in the collective utility function of modes (see Equation (3)):

$$V_i^{2Car} = \lambda_i \cdot \alpha_F^{2Car} + (1 - \lambda_i) \cdot \alpha_M^{2Car},$$

$$V_i^{Car} = \lambda_i \cdot \alpha_F^{Car} + (1 - \lambda_i) \cdot \alpha_M^{Car},$$

where α_G^{Car} , $G = F, M$, represents the utility that the first car provides to the spouse G and α_G^{2Car} , $G = F, M$ represents the utility that the second car provides to the spouse G .

Each spouse's utility function is assumed to be linear in some individual characteristics and in some couple-specific characteristics (residence, number of children, tenure status). In this specification, the effect of the couple-specific characteristics respectively on the woman's and the man's deterministic utility can hardly be identified separately, like the fixed premium and additional VOT of travelling together in Section 5. Therefore, we rather estimate the weighted averages of both effects. Similarly, the fixed benefits of choosing the first and second cars can

hardly be identified separately for the man and for the woman so that we estimate a weighted average fixed benefit for choosing the first car and a weighted average fixed benefit of choosing a second one.

6.2.Results

To estimate this nested logit, we include households with no car in the pooled estimation sample and so the number of observed households increases to 36,997. The specification of the utilities of the different modes and of the bargaining power are assumed to be the same as in the previous model. Their parameters are estimated simultaneously with those of the car ownership model.

Most of the previous results remain true with two notable exceptions which validate the need to include automobile ownership in the description together with mode choice. The fixed premium of commuting by car together is now significantly negative and larger in absolute value when the woman drives than when the man drives. Moreover, the additional VOT of commuting together by car is slightly more negative when the woman drives than when the man drives. This result is more plausible than the one obtained with the multinomial model on the pooled sample, which suggested a very large increase in VOT when commuting together rather than alone when the woman drives, and a decrease when the man drives.

Mode choice	Pooled sample (+households without car)	
	woman	Man
	Fixed utility of commuting by car alone α_{iG}^C	
Intercept(drive alone)	-2.814 ***	-1.064 ***
x (workplace in Inner Ring)	4.107 ***	3.371 ***
x (workplace in Outer Ring)	5.268 ***	4.596 ***
x (occup="blue collar")	-0.135	0.738
x (occup=employee)	-	-
x (occup="professional")	0.778 ***	0.670 ***
x (occup="white collar")	0.737 ***	0.128
x (occup="self-employed")	3.713 ***	3.806 ***
x Foreign	-1.409 ***	-0.661 ***
x # children aged 0-3	0.204 ***	n.s
x # children aged 4-6	0.230 ***	n.s
x # children aged 7-11	0.346 ***	n.s
x # children aged 12-16	0.322 ***	n.s
	Fixed premium for commuting together $\alpha_i^{j,j'} - \alpha_i^{C^A,C^A}$	
when man drives		-1.184 ***
when woman drives		-1.588 ***
	Value of time, by mode β_{iG}^j	
By transit	2.274 ***	1.542 ***
by car, alone	4.320 ***	2.950 ***
	Ratio VOT Car/Bus	1.900
	Additional VOT when traveling together $\beta_i^{j,j'} - \beta_i^{C^A,C^A}$	
when man drives		-0.761 ***
when woman drives		-1.262 ***
x (age-40)/10	-0.059	-0.311 ***
x (occup="blue collar")	-1.105 ***	-0.318
x (occup=employee)	-	-
x (occup="professional")	1.092 ***	0.521 **
x (occup="white collar")	2.107 ***	3.082 ***
x (occup="self-employed")	-0.625	0.919 **

Choice of a second car			
Intercept (2 cars)		-2.124***	
x (age-40)/10	0.537	***	0.357 ***
x Foreign	-0.397	***	-0.403 ***
x # children aged 0-16		0.071***	
x (residence in Inner Ring)		1.085***	
x (residence in Outer Ring)		1.180***	
Inclusive variable (1 car)		2.300***	
Inclusive variable (2 cars)		2.156***	
Choice of a first car			
Intercept (1 car)		0.036	
x (age-40)/10	0.685	***	0.229 **
x Foreign	-0.897	***	-1.665 ***
x # children aged 0-16		0.198***	
x (residence in Inner Ring)		1.287***	
x (residence in Outer Ring)		1.723***	
Inclusive variable (0 car)		0.240***	
Inclusive variable (1+ car)		0.830***	
Woman's bargaining power			
x (woman's age-man's age)/10	-0.016		
x (both spouses are French)	-		
x (both spouses are foreign)	0.133	*	
x (foreign woman & French man)	0.144	*	
x (French woman & foreign man)	-0.053		
x (tenure status=homeownership)	0.126	***	
x (neither spouses have temporary contract)	-		
x (both spouses have temporary contract)	0.260	**	
x (only woman has temporary contract)	-0.062		
x (only man has temporary contract)	0.400	***	
x # children	-0.037	***	
# observations		36997	
Log-likelihood		-56649	
Pseudo-R ²		38.3%	

Table 9: Estimation results of car ownership and mode choice nested logit
Significant at: *** 1% level; ** 5% level; * 10% level

The probabilities to acquire a first and a second car are estimated simultaneously with the mode choice probabilities. For these car ownership choices, the reference spouses are 40-year-old French individuals without children living in Paris. The benefit of owning a car increases with the spouses' age (more significantly for women than for men) and with the number of children (in particular the benefit of the first car). Compared to the reference (residence inside Paris), the probability to own a car is larger when the couple lives in the Inner ring, and even larger when living in the Outer ring. This illustrates the higher difficulty of parking but also the greater supply of transport infrastructures in Paris.

As shown on Figure 6, the probability that the man drives is larger for short commuting times (lower than 40 min), while the woman has more chance to be the driver for long travels (more than 40 min). Spouses are more likely to commute by car alone than together when commuting time is short (less than 1 hour 10 minutes if the woman drives, less than 1 hour 40 minutes if the man drives).

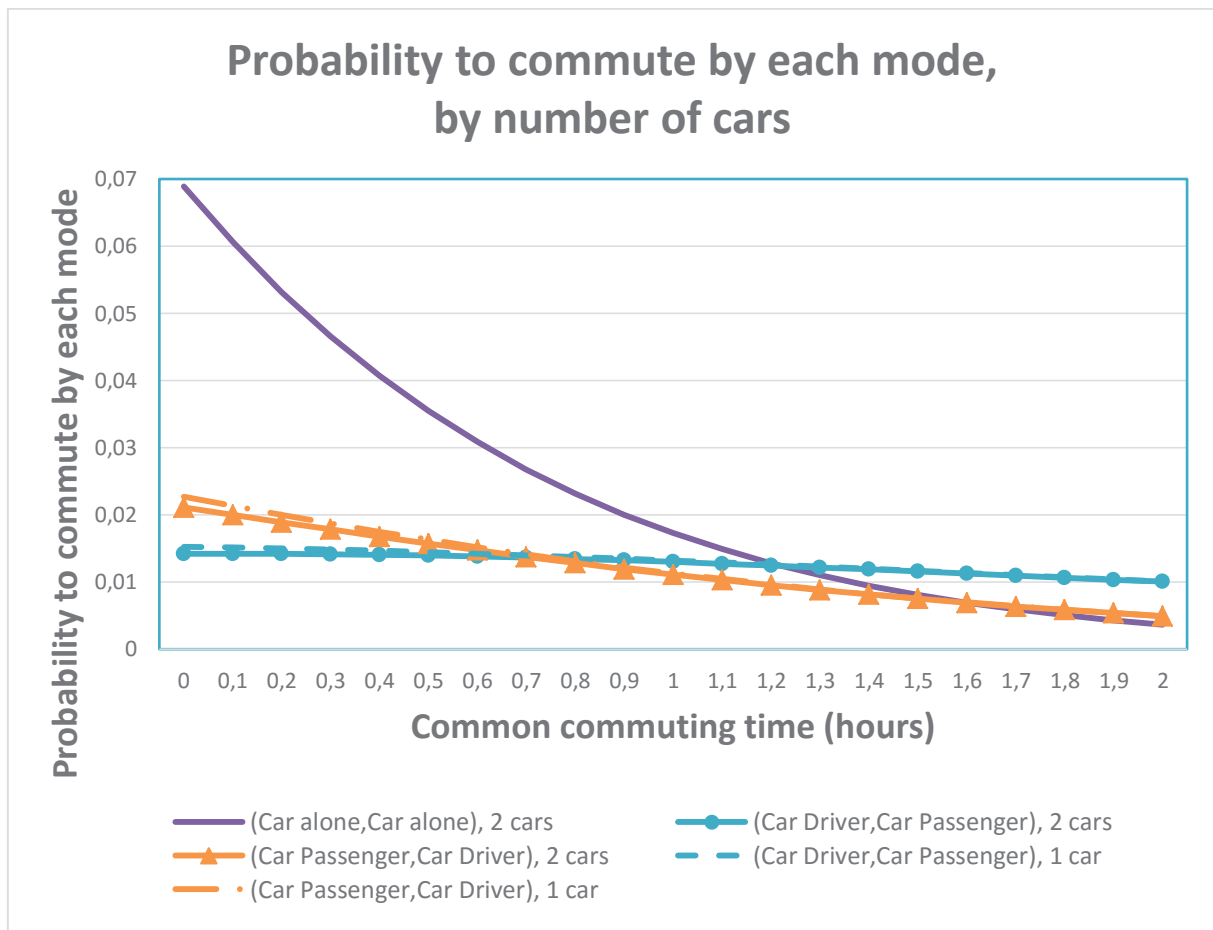

Figure 6: Probability to commute by car alone and together, as a function of common commuting time (same workplace for both spouses). Nested model.

7. Conclusions and extensions

Values of time is typically estimated for men and women considered as independent decision makers, i.e. without taking care of the interaction in the couple and in particular ignoring the bargaining power in the couple. We have modelled here this bargaining power and highlighted empirically its determinants. When there is only one car that each active spouse wishes to use for commuting, the situation is more involved, and the family context matters.

We have considered the study of mode choice in Paris region. For this study, we have demonstrated the inability of the standard independent choice model to reproduce the intra-household mode-choice decision process within two-earner couples. To describe appropriately joint mode choice decisions, we have set-up a structural collective model. This model provides more plausible results and exhibits a greater predictive power. However, the parameters of this collective model must be estimated simultaneously with the parameters of a car ownership model, in order to avoid biases due to endogeneity of the number of cars jointly chosen by the household. To address the endogeneity issue, we model the combined choice of the number of cars and commuting.

Economics of the family also matters in the long run (see Chiappori et al., 2014). In this case, the joint decision concerns residential location and work location choices. Such decisions are

also interrelated with access to automobile. Modelling mode choice within couples might then enable to determine the long term effects on urban development when couples' bargaining process is taken into account.

The difference between the VOT of driving alone and the VOT of commuting together underlines that being accompanied rather than alone and being the passenger rather than the driver have strong effects on the VOT. These effects have different implications on carpooling, as far as who is driving and how the costs are shared. Our estimates show that there is a positive premium for the spouses to drive together. The average VOT of the reference couple is reduced by 20.9% when the man drives and by 34.7% when the woman drives. Using the 12.6 €/h official value in Paris area recommended by Quinet (2014), this represents a reduction of 2.64 €/h when the man drives, and 4.37 €/h when the woman drives. Carpooling is likely to affect the value of time, but likely in a qualitative different manner: being accompanied decreases the (average) value of time of spouses but may increase that of ridesharing people who do not know each other. Our methodology could potentially be adapted to compute these premia/penalties in the context of carpooling, which modal split has been rapidly growing during the last decade.

How the interaction between being accompanied and being a passenger affect the VOT of commuting by car is also relevant when assessing the benefits of the automated vehicles since such vehicles constitute the only transport mode which enable an individual to commute by car as passenger while being alone (see International Transport Forum, 2015). The difference of VOT between the passenger and the driver depending on which spouse is the driver will be assessed in our future work.

Acknowledgements

This paper benefited from the comments of participants in the *Applied Micro and Development Workshop* organized by THEMA (University of Cergy Pontoise) and ESSEC, in the symposium *Advances in Family Economics and Applications to Developing Countries 2013* organized by Economix (University Paris Ouest Nanterre) and at the *ITEA Annual Conference Kuhmo Nectar 2015*. This research has been conducted as part of the project Labex MME-DII (ANR11-LBX-0023-01) as well as the ANR ELITISME project.

References

- [1] Abraham, J.E., Hunt, J.D., 1997. Specification and estimation of nested logit model of home, workplaces, and commuter mode choices by multiple-worker households, *Transportation Research Record* 1606, 17-24.
- [2] Anas, A., Moses, L.N., 1979. Mode choice, transport structure and urban land use, *Journal of Urban Economics* 6 (2), 228-246
- [3] Anas, A., Xu, R., 1999. Congestion, land use, and job dispersion: A general equilibrium model. *Journal of Urban Economics* 45(3), 451-473.
- [4] Anderson, S., de Palma, A., Thisse, J.-F., 1992. *Discrete choice Theory of Product differentiation*, MIT Press, Cambridge.
- [5] Becker, G., 1965. A theory of the allocation of time, *Economic Journal* 13, 494-517.
- [6] Becker, G., 1991. *A Treatise on the Family*, Harvard University Press.
- [7] Beharry-Borg, N., Hensher, D., Scarpa, R., 2009. An analytical framework for joint vs separate decisions by couples in choice experiments: The case of coastal water quality in Tobago, *Environmental and Resource Economics* 43(1), 95-117.
- [8] Ben-Akiva, M. E., Lerman, S. R., 1985. *Discrete Choice Analysis: Theory and Application to Travel Demand*, MIT Press, Cambridge, Ma.
- [9] Bhat, C.R., Pendyala, R.M., 2005. Modeling intra-household interactions and group decision-making, *Transportation* 32, 443-448.
- [10] Bronner, A., 1982. Decision Styles in Transport Mode Choices, *Journal of Economic Psychology* 2, 81-101.
- [11] Browning, M., Chiappori, P.-A., Weiss, Y., 2014. *Economics of the Family*, Cambridge Books, Cambridge University Press.
- [12] Chiappori, P.A., 1988. Rational household labor supply, *Econometrica* 56(1), 63-90.
- [13] Chiappori, P.A., 1992. Collective labor supply and welfare, *Journal of Political Economy* 100(3), 437-467.
- [14] Chiappori, P.A., de Palma, A., Inoa, I., Picard, N., 2014. Residential location choice and household decision, Mimeo, Columbia University.
- [15] Chiappori, P.A., Fortin, B., Lacroix, G., 2002. Marriage market, divorce legislation, and household labour supply, *Journal of Political Economy* 110(1), 37-72.
- [16] De Donnea, F.X., 1971. *The determinants of transport mode choice in Dutch cities*, Rotterdam University Press, Rotterdam.
- [17] de Palma, A., Lindsey, R., Picard, N., 2015. Trip-timing decisions and congestion with household scheduling preferences, *Economics of Transportation* 4 (1-2), 118-131.
- [18] de Palma, A., Inoa, I., Picard, N., 2014. Discrete Choice Decision-Making with Multiple Decision Makers within the Household, in Hess, S., Daly, A. (Eds.), *Handbook of Choice Modelling*, Edward Elgar publishers, Cheltenham, 363-382.
- [19] de Palma, A., Marchal, F., 2002. Real Cases Applications of the Fully Dynamic METROPOLIS Tool-Box: An Advocacy for Large-Scale Mesoscopic Transportation Systems, *Networks and Spatial Economics* 2 (4), 347-369.
- [20] DRIEA, 2013. Enquête globale des transports. Motorisation et usage de la voiture en Ile-de-France, OMNIL.
- [21] International Transport Forum, 2015. Automated and Autonomous Driving: Regulation under uncertainty, Organization for Economic Co-operation and Development (OECD)
- [22] Kroes, E., Kouwenhoven, M., Debrincat, L., Pauget, N., 2014. Value of Crowding on Public Transport in Île-de-France, France, *Transportation Research Record: Journal of the Transportation Research Board* 2417, 37-45.
- [23] Lerman, S. R., 1977. Location, housing, automobile ownership, and mode to work: a joint choice model, *Transportation Research Record* 610, 6-11.

- [24] Lundberg, S., Pollak, R.A., 1993. Separate Spheres Bargaining and the Marriage Market, *Journal of Political Economy* 101(6), 988-1010.
- [25] McFadden, D., Train, K., 2000. Mixed MNL models for discrete response, *Journal of Applied Econometrics* 15(5), 447-470.
- [26] McElroy, M., Horney, M., 1981. Nash-Bargained Decisions: Toward a Generalization of the Theory of Demand, *International Economic Review* 22, 333-349.
- [27] Moses, L. Williamson, H. 1963. Value of Time, Choice of Mode, and the Subsidy Issue in Urban Transportation, *Journal of Political Economy* 71, 247-264.
- [28] Picard, N., de Palma, A., Inoa, I., 2015. Intra-household Decision models of Residential and Job Location, in: Bierlaire, M., de Palma, A., Hurtubia, R., Waddell, P. (Eds.), *Integrated transport and land use modeling for sustainable cities*, EPFL Press.
- [29] Picard, N., de Palma, A., Dantan, S., 2013. Intra-household discrete choice models of mode choice and residential location. *International Journal of Transport Economics*, 40 (3), 419-445.
- [30] Timmermans, H.J., 2006. Analyses and models of household decision making processes. Resource paper for the workshop on "group behavior", in: Proceedings of the 11th International Conference on Travel Behaviour Research, Kyoto, Japan.
- [31] Timmermans, H.J., Zhang, J., 2009. Modeling household activity travel behavior: Examples of state of the art modeling approaches and research agenda, *Transportation Research* 43(2), 187 -190.
- [32] Train, K. McFadden, D., 1978. The goods/leisure tradeoff and Disaggregate Work Trip Mode Choice Models, *Transportation Research* 12, 349-353.
- [33] Vermeulen, F., 2002a. Collective household models: Principles and main results, *Journal of Economic Surveys* 16(4), 533-564.
- [34] Vermeulen, F., 2002b. Where does the unitary model go wrong? Simulating tax reforms by means of unitary and collective labour supply models. The case for Belgium, in: Laisney, F. (Eds.), *Welfare analysis of fiscal and social security reforms in Europe: does the representation of family decision processes matter?* in: Final report on EU-project VS/2000/0778.
- [35] Vickrey, W.S., 1969. Congestion theory and transport investment, *American Economic Review* (Papers and Proceedings) 59, 251-261.
- [36] Warner, S., 1962. *Strategic Choice of Mode in Urban Travel: A Study of Binary Choice*, Northwestern University Press, Evanston.
- [37] Wilson, A., 1965. Modal Split, paper presented at the University of London, Transportation and Urban Planning Seminar.
- [38] Quinet, E., 2014. L'évaluation socioéconomique des investissements publics, Commissariat général à la stratégie et à la prospective